



Aluminum electrolytic capacitors

Snap-in capacitors

Series/Type: **Base cooling**
Date: December 2010

Snap-in capacitors for base cooling

Applications

- Frequency converters or power supplies with heat sink
- DC links with ultra high ripple current load per capacitance, extra long useful life or superior reliability requirements.

Features

- Reduced overall length tolerance (± 0.2 mm) for effective heat sink mounting of capacitor banks
- Suited for use of thin thermal pads
- Minimized and long term low thermal resistances between base and winding
- Extremely high ripple current load and long useful life
- Outstanding low ESR at operating conditions above 50 °C
- Available upon request for different 85 °C and 105 °C series
- Case size range from 30 × 35 mm to 35 × 55 mm
- Capacitors with all insulation versions pass the needle flame test according to IEC 60695-11-5 for all flame exposure times up to 120 s
- RoHS-compatible

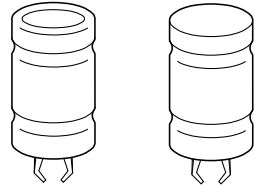

Construction

- Charge/discharge-proof, polar
- Reinforced aluminum can with long term rigidity
- Standard insulation: PET sleeve without insulation sheet at the can bottom
- Version without insulation available
- Snap-in solder pins to hold component in place on PC-board
- Minus pole marking on case surface (insulated version only)
- Minus pole not insulated from case
- Overload protection by safety vent on the case wall

Terminals

- Standard version with 2 terminals, 2 lengths available: 6.3 and 4.5 mm
- 3 terminals to ensure correct insertion: length 4.5 mm

Capacitors with base cooling feature for heat sink mounting are available upon request for series B43540, B43543, B43505. As an option, the capacitors can be equipped with suitable thermal pads. Please refer to chapter "General technical information, 5.2 Cooling" for more details regarding thermal management.

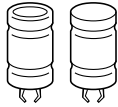

Dimensional drawings

Snap-in capacitors with PET sleeve insulation for base cooling

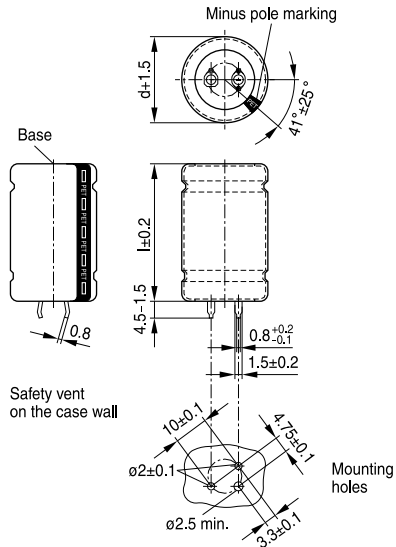
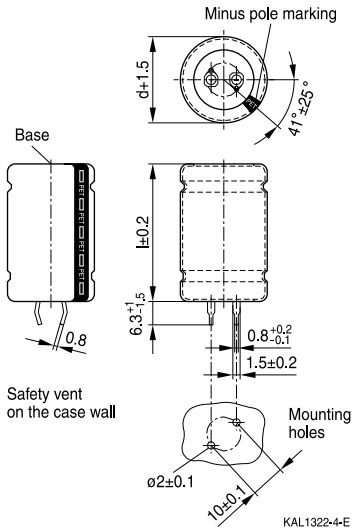

Snap-in terminals, length $(6.3 +1/-1.5)$ mm. Also available in a shorter version with a length of $(4.5 -1.5)$ mm. Without insulation sheet at the base.

PET insulation is marked with label "PET" on the sleeve.

Snap-in capacitors are also available with 3 terminals (length $(4.5 -1.5)$ mm). Without insulation sheet at the base. PET insulation is marked with label "PET" on the sleeve.

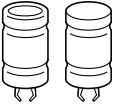

Base cooling

Snap-in capacitors without insulation for base cooling

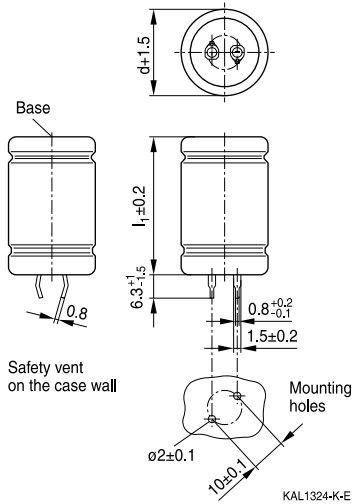

Snap-in terminals, length $(6.3 +1/-1.5)$ mm.
Also available in a shorter version with a length of $(4.5 -1.5)$ mm. Marking by an adhesive label.

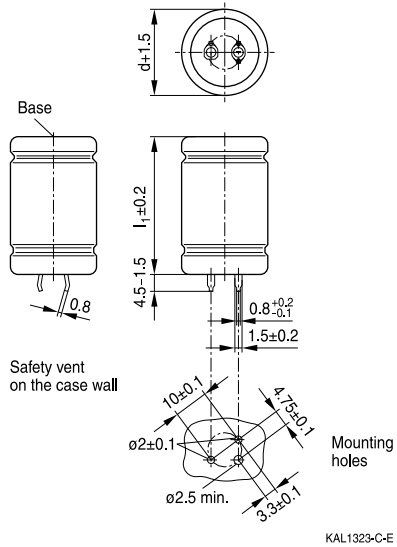

Snap-in capacitors are also available with 3 terminals (length $(4.5 -1.5)$ mm). Marking by an adhesive label.

Important notes

The following applies to all products named in this publication:

1. Some parts of this publication contain **statements about the suitability of our products for certain areas of application**. These statements are based on our knowledge of typical requirements that are often placed on our products in the areas of application concerned. We nevertheless expressly point out **that such statements cannot be regarded as binding statements about the suitability of our products for a particular customer application**. As a rule, EPCOS is either unfamiliar with individual customer applications or less familiar with them than the customers themselves. For these reasons, it is always ultimately incumbent on the customer to check and decide whether an EPCOS product with the properties described in the product specification is suitable for use in a particular customer application.
2. We also point out that **in individual cases, a malfunction of electronic components or failure before the end of their usual service life cannot be completely ruled out in the current state of the art, even if they are operated as specified**. In customer applications requiring a very high level of operational safety and especially in customer applications in which the malfunction or failure of an electronic component could endanger human life or health (e.g. in accident prevention or lifesaving systems), it must therefore be ensured by means of suitable design of the customer application or other action taken by the customer (e.g. installation of protective circuitry or redundancy) that no injury or damage is sustained by third parties in the event of malfunction or failure of an electronic component.
3. **The warnings, cautions and product-specific notes must be observed.**
4. In order to satisfy certain technical requirements, **some of the products described in this publication may contain substances subject to restrictions in certain jurisdictions (e.g. because they are classed as hazardous)**. Useful information on this will be found in our Material Data Sheets on the Internet (www.epcos.com/material). Should you have any more detailed questions, please contact our sales offices.
5. We constantly strive to improve our products. Consequently, **the products described in this publication may change from time to time**. The same is true of the corresponding product specifications. Please check therefore to what extent product descriptions and specifications contained in this publication are still applicable before or when you place an order. We also **reserve the right to discontinue production and delivery of products**. Consequently, we cannot guarantee that all products named in this publication will always be available. The aforementioned does not apply in the case of individual agreements deviating from the foregoing for customer-specific products.
6. Unless otherwise agreed in individual contracts, **all orders are subject to the current version of the "General Terms of Delivery for Products and Services in the Electrical Industry" published by the German Electrical and Electronics Industry Association (ZVEI)**.
7. The trade names EPCOS, BAOKE, Alu-X, CeraDiode, CSMP, CSSP, CTVS, DeltaCap, DigiSiMic, DSSP, FormFit, MiniBlue, MiniCell, MKK, MKD, MLSC, MotorCap, PCC, PhaseCap, PhaseCube, PhaseMod, PhiCap, SIFERRIT, SIFI, SIKOREL, SilverCap, SIMDAD, SiMic, SIMID, SineFormer, SIOV, SIP5D, SIP5K, ThermoFuse, WindCap are **trade-marks registered or pending** in Europe and in other countries. Further information will be found on the Internet at www.epcos.com/trademarks.